

PRO-CUT[®]

HIGH VOLUME MEAT GRINDERS



KG-32



KG-32-XP

These units provide high efficiency on grinding process and reduce the working time for high volume production

MODEL:

KG-32, KG-32 MP, KG-32-XP

- High grinding capacity (More than 1700 kg / 3,800 lb per hour in the first ground).
- High grade stainless steel cabinet and tray.
- 3 or 5 HP motor.
- Easy to clean without tools.
- Expedites customer service.
- High capacity head design and deep pan.
- Thermomagnetic contactor protects the motor against overloads.
- Leveling feet
- Powerful gear transmission



MODEL: KG-32, KG-32 MP, KG-32-XP



EASY TO CLEAN

Its practical grinding system and the feed pan can be completely disassembled in a few minutes without tools reducing time spent on cleaning and maintenance operations.

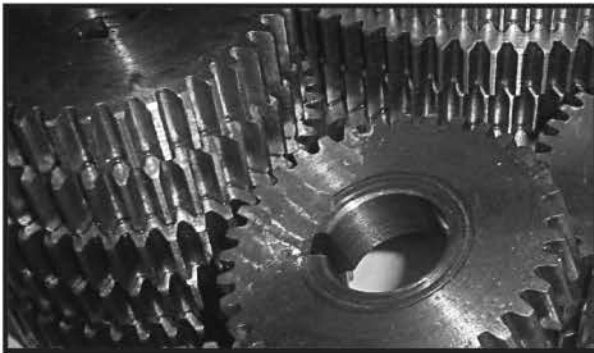

LONG LASTING LIFE

The powerful oil bathed steel gears transmission (with no belts or pulley to maintain) guarantees a long lasting life, with minimum noise and low maintenance cost.



DEFLECTOR ON THE HEAD

To avoid product's spatter that could exist due to air pockets in this powerful equipment.



HIGH VOLUME CAPACITY

Its high capacity head holds bigger pieces into the grinding system, avoiding down time in cutting into smaller pieces. Cast iron grinding components with dip tin plating.



LARGE CAPACITY AND SAFETY OPERATION

The KG-32 and KG-32-XP are equipped with a safety protector guard in the feeding area. However the stomper must always be used.



STAND FOR KG-32-XP INCLUDED

All specifications are subject to change without notice.

DIMENSIONS

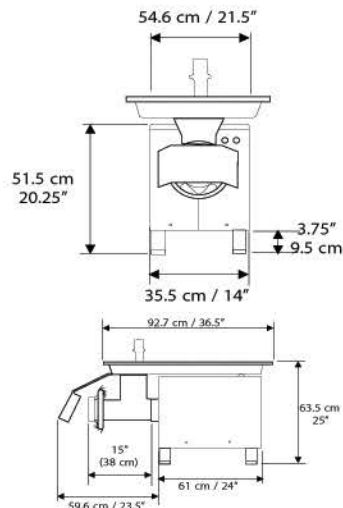
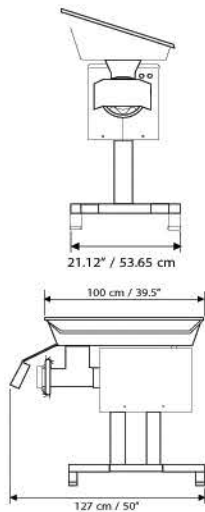

MINIMUM MAINTENANCE

- Powerful oil bathed steel gears transmission, with no belts or pulleys to maintain

HYGIENIC

- High grade stainless steel cabinet and tray, high corrosion resistant and easy to clean allowing a hygienic operation and a professional presentation.
- Includes knife, plate and stomper.

SPECIFICATIONS:

MODEL	KG-32-MP	KG-32	KG-32-XP
*MOTOR	3hp/2.23kw single phase	3hp/2.23kw three phase	5hp/3.72KW three phase
VOLTS	220/440 v	220/440 v	220/440 v
FREQUENCY	50/60 hz.	50/60 hz.	50/60 hz.
Grinding C. (3/8) First Ground	25kg/min 55lb/min	25kg/min 55lb/min	29kg/min 64lb/min
Grinding C. (1/8) second Ground	13kg/min 29lb/min	13kg/min 29lb/min	14kg/min 31lb/min
NET WEIGHT	118kg/260.48 lb	118kg/260.48 lb	123kg/272 lb
SHIPPING WEIGHT	140kg/309 lb	140kg/309 lb	152kg/336 lb
LEVELING FEET	YES	YES	YES

*Motor available 110 volts/60 Hz or 220 Volts/ 50 Hz optional

** 35°F/2°C Fresh Meat, lab conditions



DOSZE
EQUIPMENT
WWW.DOSZE.COM.CO
Bogota D.C. ventas@dosze.com.co

These meat grinders are the ideal solution to handle high volume production. They feature a great production capacity.

